

NUCLEAR GAGING

Controls

Abrasive Coating Thickness

Reprinted from



June 9, 1952

INDUSTRIAL NUCLEONICS CORPORATION

COLUMBUS, OHIO

NUCLEAR GAGING

Controls

Abrasive Coating Thickness

Integration of continuous beta-ray gaging with production control on an automatic basis permits thickness and density of adhesive and abrasive to vary no more than one per cent

A RADICAL new production technique installed at Carborundum Co.'s Coated Products Division plant, Niagara Falls, N. Y., is expected to set new standards of precision in the manufacture of coated abrasives. With the production setup, Carborundum can control thickness and density of adhesive, abrasive and final adhesive coat with an accuracy within one per cent.

Gages Integrated—The new technique, worked out with specialists of the Industrial Nucleonics Corp., Columbus, O., integrates five Accuray beta-ray gages, actuated by radioisotopes, into the coated-abrasive machine production line. Nuclear gaging is fast and super-accurate, so that automatic production control in the industry is at last commercially feasible. The five gages continuously assess weight of backing, weight of adhesive, weight of abrasive, weight after precure, and weight after final adhesive application on a line that travels up to 350 feet per minute.

Carborundum says this installation is the first of its type in the abrasives field. Up to now, production control in the estimated \$90-million-a-year industry has been on a cut-and-try basis. This required stopping of machinery, cut-

ting out an edge sample, checking the sample, readjusting rolls and feeds. Overshooting on specifications was common to make sure of meeting minimum thickness and density standards.

Each Run Recorded—Radioisotope gaging on a continuous basis provides permanent graphic records of each run. Its adaptability to automatic control not only eliminates the costly and inaccurate manual testing, but also reduces machine downtime, allows savings in the expensive materials used (resins, adhesives, aluminum oxide, silicon carbide, garnet), and prevents wastage of processed materials.

The Accuray gages are not influenced by outside factors such as temperature, dirt, or humidity. They do not contact the moving sheet at any time. In each gage, a sealed capsule of radioactive strontium-90 emits beta rays. As the material being measured moves past the aperture between the sources and the detector unit (a special type of ionization chamber), the amount of radiation passing through the material varies according to the density of the material.

The beta rays that get through to the detector unit ionize a gas

and thus create a voltage that provides a recording and controlling signal. Since the gage is calibrated, variations in beta-ray transmission cause changes in signal that vary directly with change in weight per unit area. Recalibration is never necessary. The radioactive isotope is inspected every six months although its life is 30 years.

Five Gages per Machine — At Carborundum, each machine requires five Accuray gages. Gage No. 1 measures backing weight. This backing is usually paper, cloth, fiber, or combination. Variation in unit weight at this point affects future coating operations, such as adhesive roll setting. Gage No. 2 picks up weight of backing plus weight of adhesive coat.

Gage No. 3 measures weight of backing plus weight of adhesive, plus weight of abrasive. Gage No. 4 measures total weight after preliminary cure and before the final adhesive application. Gage No. 5 measures final weight after this last adhesive application.

Signals from the gages are translated into a trace on pen recorders. Superimposing the trace signal from gage No. 1 and the signal from gage No. 2 (each a different color) on one recorder, provides



Radioactive isotope — strontium-90 — provides beta-rays that actuate gage for continuous measurement of unit weight and density as backing material passes through the abrasive coating machine at 350 fpm

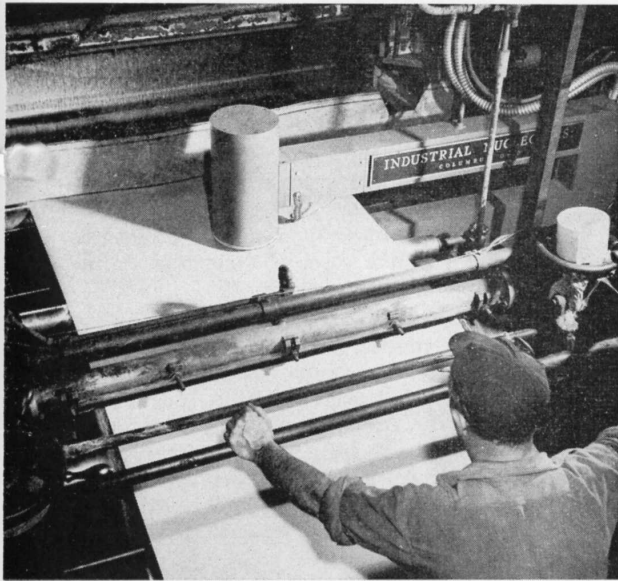

Second gage measures weight of backing plus weight of adhesive as material moves through coating machine. Abrasive material (background) streams onto the adhesive-coated backing in closely controlled quantity

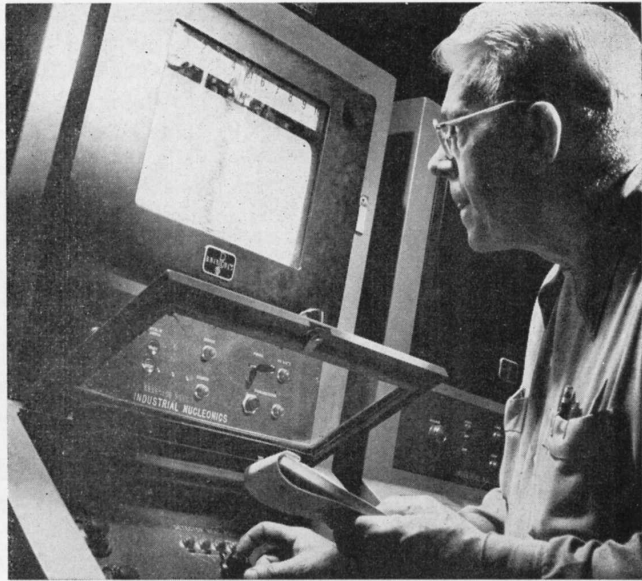

Recorders, synchronized with speed of material passing through abrasive coating machine, give continuous indication of whether specifications are being met. These records can be kept permanently for reordering

a visual comparison of machine coating. The two superimposed signals from gage No. 2 and gage No. 3 on a second recorder shows immediately any deviation from specification. When the two traces overlap, the material is being made properly. Any change is immediately noted. With its source known, proper correction in ad-

hesive roll setting, abrasive feed, final adhesive roll setting, or speed of paper through the machinery can be made.

Coatings Uniform—A setup like this makes it possible to produce on a practical manufacturing basis uniform coatings despite lot-to-lot

variations in backing materials, the slightest variation in flow of adhesive or abrasive onto the moving web, or variation in machine speed. In conventional manufacture, such errors tend to compound and might cause complete rejection of the finished product with

Schematic sketch indicates how precise gaging is combined with close production control in coated abrasive manufacture at the Carborundum Co.

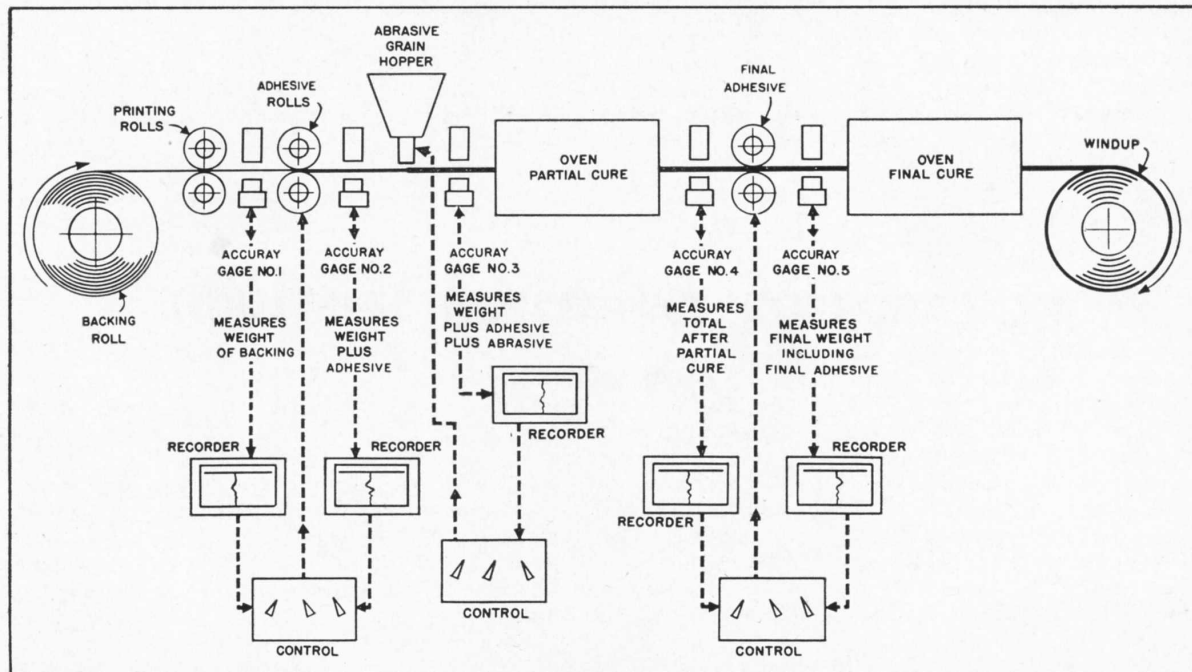

resultant loss of valuable production time.

Production significance of the installation in bringing super-accuracy to a tough processing problem will reach into the user industries too. It is expected that customers will not only benefit from improved quality but that techniques will correspondingly improve, making practical even closer precision in metalworking.

Coated abrasives are used in practically every manufacturing activity. The commercial product comes in rolls, disks, belts, pads with many variations in the abrasive material (aluminum oxide or silicon carbide) and to many speci-

fications of thickness and density of abrasive, resin or adhesive coats, or backing.

Affects Performance—Each of these components and its amount on a given area has an effect on performance of the coated product in stock removal and product finishing. Also, modern precision grinding methods have inevitably led users to demand very close control of coated abrasives.

Since manufacture is a continuous process, makers have been scratching their heads for years looking for a way to control the various feeds on the fast-moving machinery to produce products to strict specification. Progress in

backing materials, adhesives, high-performance abrasive materials has been steady in the industry. But progress in production control has lagged behind the procession.

Integration of continuous gaging with production control on an automatic basis is expected to pay for itself in a matter of months on the basis of savings to Carborundum alone.

The company is finding other plusses, too. Process control is relatively simple, requires no additional operator skills. It is actually easier than previous methods. The gages are fitted with traversing controls that permit measurement at any desired point across the traveling web being processed.